



CHAIN HOIST CH-B TYPE



Model		CHB005	CHB010	CHB015	CHB020	CHB030	CHB050	CHB075	CHB100	CHB200	CHB300	CHB500
Capacity	t	0.5	1	1.5	2	3	5	7.5	10	20	30	50
Standard Lift	m	2.5	2.5	2.5	3	3	3	3	3	3	3	3
Proof Load	kN	7.35	14.7	22.1	29.4	44.1	73.5	110.2	147	245	367.5	612.5
Effort Required to Lift Rated Load	N	200	320	360	365	385	435	435	435	435X2	435X2	435X2
No. of Falls of Load Chain		1			2		3		4		8	
Load Chain	mm	6x18			8x24			10x30				
Dimensions(mm)	A	137.5	146.5	170	170	170	190	190	190	209	312	496
	B	137	162	183	194	220	288	377	384	625	691	958
	C	270	317	399	414	465	636	768	798	890	1380	2578
	D	35	35.5	45	42.5	50	65	64	85	110	110	170
	K	28	26	32.5	32	37	46	46	50	81	81	125
Net Weight	kg	8.7	10.6	15.2	18	24.3	38.7	61.6	78	163.6	220	1092
Extra Weight per Metre of Extra Lift	kg	1.6	1.6	2.2	2.2	3.6	5.2	7.5	9.5	19	27.7	49.4

Remark: Hoists with the lift in other length are also available.

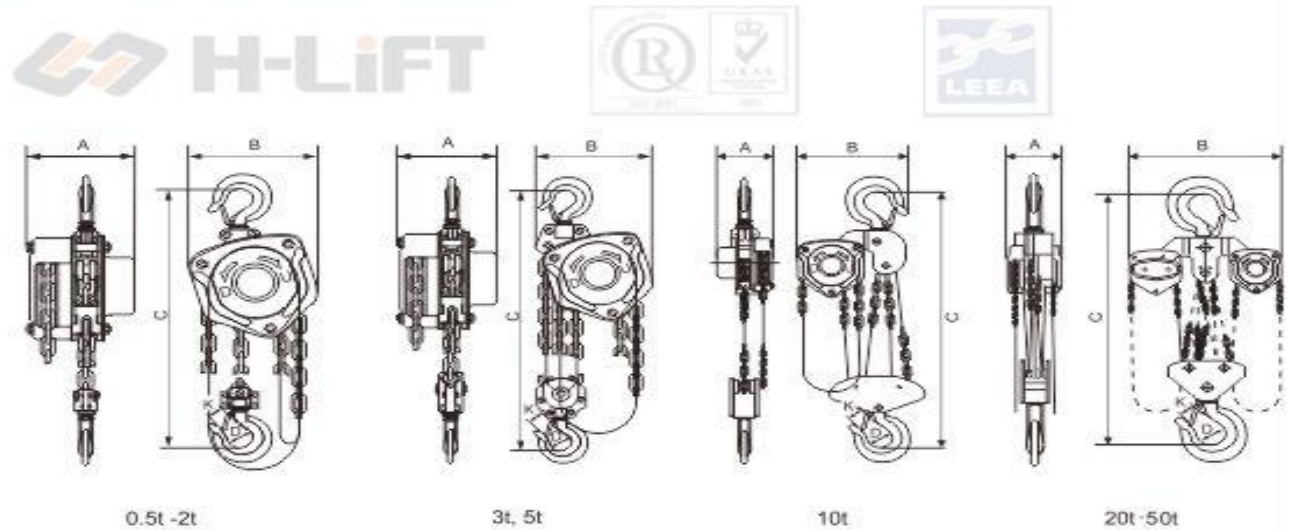

0.5t -2t

3t, 5t

10t

20t -50t